

Installation Procedures for STYROFOAM Ag Board Insulation

For more than 50 years, STYROFOAM® Ag Board extruded polystyrene insulation has helped agricultural building owners control the building's indoor environment and protect its contents, whether livestock, crops or equipment. In addition to its exceptional insulating value, STYROFOAM Ag Board resists moisture infiltration, withstands high-pressure cleaning and reduces the potential for moisture condensation within the wall.

The easy-to-install STYROFOAM Ag Board uses shiplapped edges to create a secure joint that does not require taping, saving considerable installation time.

Materials Checklist

To install STYROFOAM Ag Board, you will need:

- Utility knife or small handsaw
- Safety glasses
- Straight edge
- Measuring tape
- Pencil
- Fasteners and poly washers (such as QUIK Cap Washer-Plastic Round or Buildex Multi-Diameter Insulation Tekes)
- Polystyrene-compatible polyurethane spray foam sealant, such as GREAT STUFF™ insulating foam sealant
- STYROFOAM All-Purpose Tape (optional)
- Squeegee or soft paint roller (optional)

Installation

1. There are two ways to cut STYROFOAM Ag Board. One way is to use a straight edge and a utility knife or handsaw. Or, use a knife to score the STYROFOAM Ag Board. Then break the board over the edge of a table or sawhorse.
2. Attach STYROFOAM Ag Board perpendicular to framing, spanning at least three framing members with insulation board joints breaking over framing or meeting the roof edge. Penetrate separate wood and metal framing 1" with a corrosion-resistant fastener and poly washer, such as QUIK Cap. When fastening to metal, Buildex Multi-Diameter Insulation Tekes or equivalent (with minimum 1-1/4" poly washers) are advised.

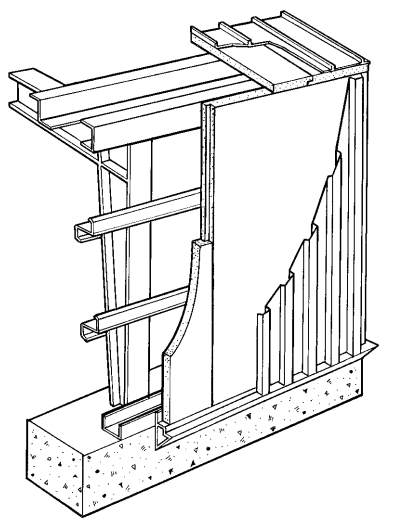

Figure 1

3. Lock the shiplapped edges together.

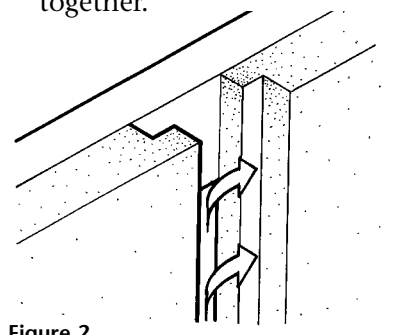

Figure 2

4. For maximum protection against moisture and air infiltration, seal the board end joints with STYROFOAM All-Purpose Tape. Use a squeegee or soft paint roller to press the tape firmly to the joint. Cut tape with a knife or scissors. Do not tear tape.

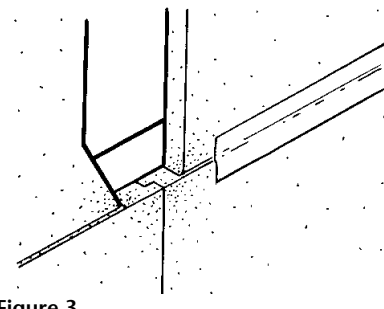

Figure 3

End-joint gaps that are greater than 1/8" should be filled with spray foam such as GREAT STUFF Gaps & Cracks sealant or equivalent to keep a continuous air infiltration barrier and to help ensure maximum thermal efficiency across the board joints. To increase the moisture effectiveness of the board joints, apply STYROFOAM All-Purpose Tape over the sprayed board joints.

IN THE U.S.:

- For Technical Information: **1-866-583-BLUE (2583)**
- For Sales Information: **1-800-232-2436**

THE DOW CHEMICAL COMPANY

- Building & Construction • 200 Larkin • Midland, MI 48674 • www.insulateyourhome.com

NOTICE: Changes to the International Residential Code require the installation of a weather-resistive barrier (WRB) within most exterior wall assemblies in residential construction. The following Dow insulated sheathing products qualify as a WRB when installed according to the installation instructions developed for "installation of foam sheathing as a weather-resistive barrier": STYROFOAM DURAMATE* Plus, STYROFOAM Residential Sheathing, STYROFOAM Tongue and Groove, STYROFOAM Square Edge, STYROFOAM Residing Board, THERMAX*, TUFF-R* and Super TUFF-R and therefore do not require the use of a building paper or a housewrap as a WRB. When a WRB is not needed, these Dow foam sheathings may be installed according to standard installation instructions for foam sheathing from Dow. Be sure products and installation instructions meet code requirements for your particular location. Note: STYROFOAM WEATHERMATE* and WEATHERMATE Plus housewraps have already qualified as weather-resistive alternatives to the prescribed felt (see Evaluation Reports NER 593 and NER 640 for approved alternative).

NOTICE: No freedom from any patent owned by Dow or others is to be inferred. Because use conditions and applicable laws may differ from one location to another and may change with time, Customer is responsible for determining whether products and the information in this document are appropriate for Customer's use and for ensuring that Customer's workplace and disposal practices are in compliance with applicable laws and other government enactments. Dow assumes no obligation or liability for the information in this document. NO WARRANTIES ARE GIVEN; ALL IMPLIED WARRANTIES OF MERCHANTABILITY OR FITNESS FOR A PARTICULAR PURPOSE ARE EXPRESSLY EXCLUDED.

COMBUSTIBLE: Protect from high heat sources. Local building codes may require a protective or thermal barrier. For more information, consult MSDS, call Dow at 1-866-583-BLUE (2583) or contact your local building inspector. In an emergency, call 1-989-636-4400.

Building and/or construction practices unrelated to insulation or housewrap could greatly affect moisture and the potential for mold formation. No material supplier including Dow can give assurance that mold will not develop in any specific system.



Living.
Improved daily.